



MXA920

Ceiling Array Microphone

User guide for Shure MXA920 ceiling array microphones. Learn how to install square and round mics, set up coverage, and quickly get great sound in any room.

Version: 0.4 (2022-E)

Table of Contents

| | | | |
|--|-----------|---|-----------|
| MXA920 Ceiling Array Microphone | 4 | Dante Channels | 19 |
| Getting Started | 4 | IntelliMix DSP | 20 |
| Designer Setup | 4 | DSP Best Practices | 20 |
| Web Application Setup | 6 | Acoustic Echo Cancellation | 20 |
| MXA920 Parts | 7 | Noise Reduction | 21 |
| Power Over Ethernet (PoE) | 8 | Automatic Gain Control (AGC) | 21 |
| Model Variations | 8 | Delay | 22 |
| Optional Accessories | 8 | Compressor | 22 |
| MXA920 Codec Certifications | 8 | Parametric Equalizer | 22 |
| What's in the Box | 8 | Encryption | 25 |
| Reset Button | 9 | Networking Best Practices | 25 |
| Reset Modes | 9 | Switch and Cable Recommendations for Dante Network- ing | 25 |
| MXA920 Control Software | 9 | Device IP Configuration | 26 |
| Controlling Devices with Shure Designer Software | 10 | Setting Latency | 26 |
| How to Update Firmware Using Designer | 10 | QoS (Quality of Service) Settings | 26 |
| MXA920 Coverage | 10 | IP Ports and Protocols | 27 |
| Add Coverage Areas | 11 | Digital Audio Networking | 28 |
| Prevent Unwanted Sounds | 13 | Compatibility with Dante Domain Manager | 28 |
| Use Steerable Lobes | 13 | Dante Flows for Shure Devices | 28 |
| Adjust Levels | 13 | AES67 | 29 |
| Using Designer's Optimize Workflow | 14 | Sending Audio from a Shure Device | 29 |
| Mute Sync | 15 | Receiving Audio from a Device Using a Different Audio Network Protocol | 29 |
| How to Install the MXA920 | 15 | Paint the MXA920 | 29 |
| NOTICE | 16 | Painting Square Array Microphones | 30 |
| Installing in a Ceiling Grid | 16 | Painting Round Array Microphones | 31 |
| VESA Standardized Mounting | 19 | Using Command Strings | 37 |
| Suspending from the Ceiling | 19 | Integrate the MXA920 with Camera Control Systems | 38 |
| Hard Ceiling Mounting | 19 | | |

| | | | |
|---------------------------|-----------|--------------------------------------|-----------|
| Troubleshooting | 38 | IMPORTANT SAFETY INSTRUCTIONS | 42 |
| Specifications | 39 | Important Product Information | 43 |
| MXA920 Frequency Response | 40 | Information to the user | 43 |
| Dimensions | 41 | | |

MXA920

Ceiling Array Microphone

Getting Started

Designer Setup

After completing this basic setup process, you should be able to:

- Discover the MXA920 in Designer
- Add coverage areas
- Adjust DSP settings and route audio

You will need:

- Cat5e (or better) Ethernet cable
- Network switch that provides Power over Ethernet (PoE)
- Shure Designer software installed on a computer. Download at shure.com/designer.

Step 1: Install and Connect

1. Install the microphone and connect it to a PoE port on the network switch using Ethernet cable.
2. Connect your computer running Designer to the same network.
3. Open Designer. Check that you're connected to the correct network in Settings.
4. Go to Online devices. To identify devices, click the product icon to flash the lights on a device. Find the MXA920 in the list.

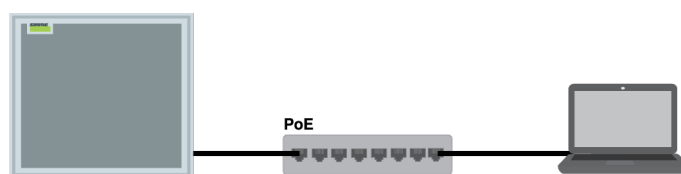

Step 2: Route Audio

The easiest way to route audio and apply DSP is with Designer's Optimize workflow. Optimize automatically routes audio signals, applies DSP settings, turns on mute synchronization, and enables LED control for connected devices.

For this example, we'll connect an MXA920 and a P300.

1. Go to My projects > New project to make a new project.
2. Select New > Room (Live). Any online devices appear in the list. Drag and drop the MXA920, P300, and any other devices to add them to your room.
3. Select Optimize. You can also route audio manually in Designer outside of the Optimize workflow, or use Dante Controller.

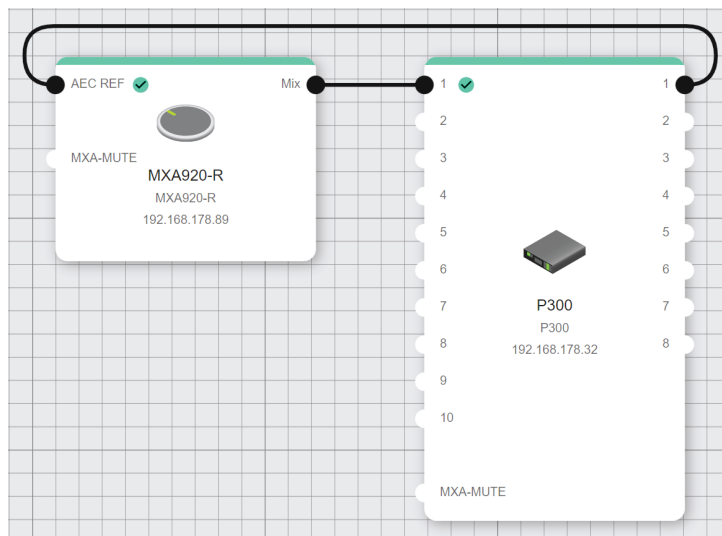

4. Check the audio routes and settings to make sure they fit your needs. You might need to:
 - Delete unnecessary routes.
 - Verify that AEC reference signals are correctly routed.
 - Fine-tune DSP blocks as needed.
5. Send audio from the P300 to other sources using the matrix mixer. A common destination is a computer connected by USB with conferencing software.

Step 3: Add Coverage

The default setting is a 30 by 30 foot (9 by 9 meter) dynamic coverage area. Any talker inside has coverage, and anything outside that area won't be picked up.

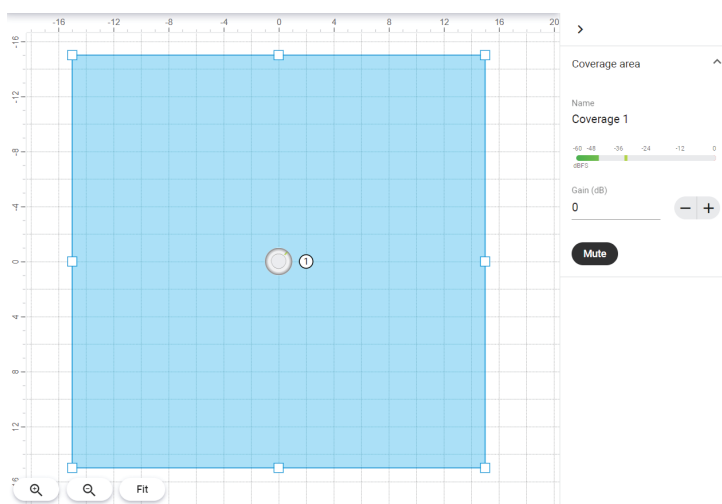

To add more coverage areas:

1. Go to [Your room] > Coverage map and select the MXA920.
2. Select Add coverage and choose a dynamic or a dedicated coverage area. You can add any combination of up to 8 coverage areas per microphone. Move and resize as needed.
3. Set up a way to listen to the microphone directly ([with a Dante headphone amp](#), for example). Place a test call with the whole conferencing system. Adjust gain and DSP as needed to get a good room sound.

You can also turn off automatic coverage in Settings to manually position up to 8 lobes.

Web Application Setup

After completing this basic setup process, you should be able to:

- Access the MXA920's web application
- Add coverage areas
- Route audio to other Dante devices using Dante Controller

You will need:

- Cat5e (or better) Ethernet cable
- Network switch that provides Power over Ethernet (PoE)
- [Shure Web Device Discovery](#) and [Dante Controller](#) software

Step 1: Install and Connect

1. Install the microphone and connect it to a PoE port on the network switch using Ethernet cable.
2. Connect the computer running Shure Web Device Discovery and Dante Controller to the same network.
3. Open Shure Web Device Discovery. Find the MXA920 in the list of devices, and double-click to open the web application.

Step 2: Add Coverage

The default setting is a 30 by 30 foot (9 by 9 meter) dynamic coverage area. Any talker inside has coverage, and anything outside that area won't be picked up.

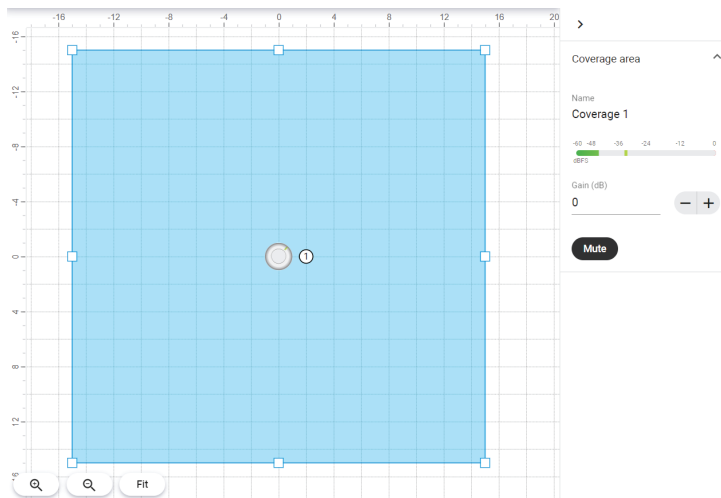

To add more coverage areas:

1. Go to Coverage > Add coverage.
2. Choose a dynamic or a dedicated coverage area. You can add any combination of up to 8 coverage areas per microphone. Move and resize as needed.
3. Set up a way to listen to the microphone directly ([with a Dante headphone amp](#), for example). Adjust the gain and DSP as needed to get a good room sound. There are gain faders for each coverage area and for the automix output.

You can also turn off automatic coverage in Settings to manually position up to 8 lobes.

Step 3: Route Audio

To route audio to other Dante devices, use Dante Controller.

1. Open Dante Controller and find the MXA920 in the list of transmitters. With automatic coverage on, the MXA920 only sends audio from the automix output. Transmit channels 1-8 only work when automatic coverage is off.
2. Find the Dante device you're sending audio to in the list of receivers. To make an audio route, check the box where the MXA920's automix output intersects with the receiver device's input channel.
3. Place a test call with the whole conferencing system. Adjust coverage, gain, and DSP as needed.

MXA920 Parts

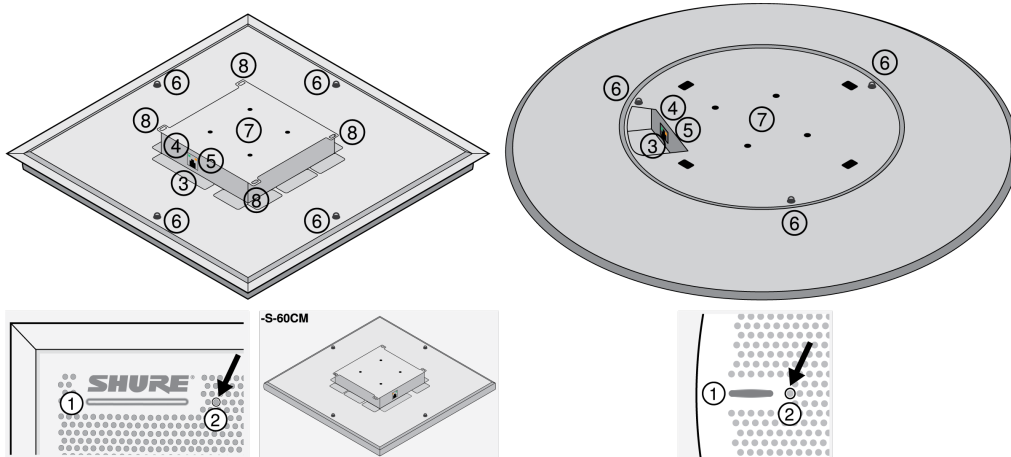

1. Mute status LED

Customize LED color and behavior in Designer: Device configuration > Settings > Lights.

Default Settings

| Microphone Status | LED Color/Behavior |
|------------------------------------|--|
| Active | Green (solid) |
| Muted | Red (solid) |
| Hardware identification | Green (flashing) |
| Firmware update in progress | Green (progresses along bar) |
| Reset | Network reset: Red (progresses along bar) Factory reset: Triggers device power-up |
| Error | Red (split, alternate flashing) |
| Device power-up | Multi-color flash, then blue (moves quickly back and forth across bar) |

Note: If LEDs are disabled, they will still turn on when the device powers up or when an error state occurs.

2. Reset button
3. RJ-45 network port
4. Network status LED (green)
 - Off = No network link
 - On = Network link established
 - Flashing = Network link active
5. Network speed LED (amber)
 - Off = 10/100 Mbps
 - On = 1 Gbps
6. Eyelet screws for suspension mounting (12 mm diameter)
7. VESA MIS-D mounting holes
8. Safety tether attachment points

Power Over Ethernet (PoE)

This device requires PoE to operate. It is compatible with **Class 0** PoE sources.

Power over Ethernet is delivered in one of the following ways:

- A network switch that provides PoE
- A PoE injector device

Model Variations

| SKU | Description |
|----------------|---------------------------------|
| MXA920W-S | White square microphone |
| MXA920W-S-60CM | White square microphone (60 cm) |
| MXA920AL-R | Aluminum round microphone |
| MXA920B-R | Black round microphone |
| MXA920W-R | White round microphone |

Optional Accessories

- [A900-S-GM Gripple Mount Kit, Square](#)
- [A900W-R-GM Gripple Mount Kit, Round, White Cover](#)
- [A900B-R-GM Gripple Mount Kit, Round, Black Cover](#)
- [A900-S-PM Pole Mount Kit, Square](#)
- [A900W-R-PM Pole Mount Kit, Round, White Cover](#)
- [A900B-R-PM Pole Mount Kit, Round, Black Cover](#)
- [A900-PM-3/8IN Threaded Rod Adapter Mounting Kit](#)

MXA920 Codec Certifications

Find MXA920 audio codec certifications at [shure.com/mxa920](https://www.shure.com/mxa920).

What's in the Box

| | |
|---|---|
| Square or round array microphone | MXA920-S or MXA920-R |
| Square or round hardware kit Square: Cable ties (8) Strain relief tabs (3) Rubber pad set Round: Cable ties (8) Strain relief tabs (3) | Square: 90A49117 Round: 90A49116 |

Reset Button



The reset button is behind the grille. To push it, use a paper clip or other tool.

Button locations:

- **Square array microphones:** Behind the grille hole with a silkscreened circle around it.
- **Round array microphones:** Behind the first grille hole to the right of the mute status LED.

Reset Modes

- **Network reset** (press for 4-8 seconds): Resets all Shure control and audio network IP settings to factory defaults. Red LED along bar.
- **Full factory reset** (press for more than 8 seconds): Resets all network and configuration settings to the factory defaults. Multicolor flash, then blue LED along bar.

MXA920 Control Software

There are 2 ways to control the MXA920:

- [Use Shure Designer software](#)
 - Control all Shure devices in one place
 - Route audio to and from Shure devices
- Access the MXA920's web application with [Shure Web Device Discovery](#)
 - Control 1 microphone at a time
 - Route audio with [Dante Controller software](#)

Controlling Devices with Shure Designer Software

To control this device's settings, use Shure Designer software. Designer enables integrators and system planners to design audio coverage for installations using MXA microphones and other Shure networked devices.

To access your device in Designer:

1. Download and install Designer on a computer connected to the same network as your device.
2. Open Designer, and check that you're connected to the correct network in Settings.
3. Click Online devices. A list of online devices appears.
4. To identify devices, click the product icon to flash the lights on a device. Select your device in the list and click Configure to control device settings.

Learn more at shure.com/designer.

You can also access device settings using [Shure Web Device Discovery](#).

How to Update Firmware Using Designer

Applies to Designer 4.2 and newer.

Before setting up devices, check for firmware updates using Designer to take advantage of new features and improvements. You can also install firmware using [Shure Update Utility](#) for most products.

To update:

1. Open Designer. If there's new firmware that you haven't downloaded yet, Designer shows a banner with the number of updates available. Click to download firmware.
2. Go to Online devices and find your devices.
3. Choose a firmware version for each device from the Available firmware column. Make sure that no one is editing device settings during an update.
4. Select the checkbox next to each device you plan to update and click Update firmware. Devices may disappear from Online devices during an update. Don't close Designer while updating firmware.

MXA920 Coverage

To access coverage map settings:

- **Designer:** Add the microphone to a room, and go to Coverage map.
- **Web application:** Go to Coverage.

To control automatic coverage, go to Settings > General > Automatic coverage.

How Much Space Does the MXA920 Cover?

For most rooms, Shure recommends:

- Maximum distance from talker to microphone: 16 feet (4.9 meters)
- Maximum mounting height: 12 feet (3.7 meters)

These numbers also depend on your room's acoustics, construction, and materials. With automatic coverage on, the default coverage area is a 30 by 30 foot (9 by 9 meter) dynamic coverage area.

How Does Coverage Work?

When you use automatic coverage, the microphone captures talkers you want to hear and avoids areas you tell it to avoid. You can add a mix of up to 8 dynamic and dedicated coverage areas per microphone.

If you turn off automatic coverage, you can manually steer up to 8 lobes.

With automatic coverage on or off, the MXA920 uses Shure's Autofocus™ technology to fine-tune coverage in real time as talkers shift positions or stand. Autofocus is always active, and you don't need to adjust anything for it to work.

Add Coverage Areas

Automatic coverage = On

When you open Coverage, there's a 30 by 30 foot (9 by 9 meter) dynamic coverage area ready to use. Any talker inside has coverage, even if they stand up or walk around.

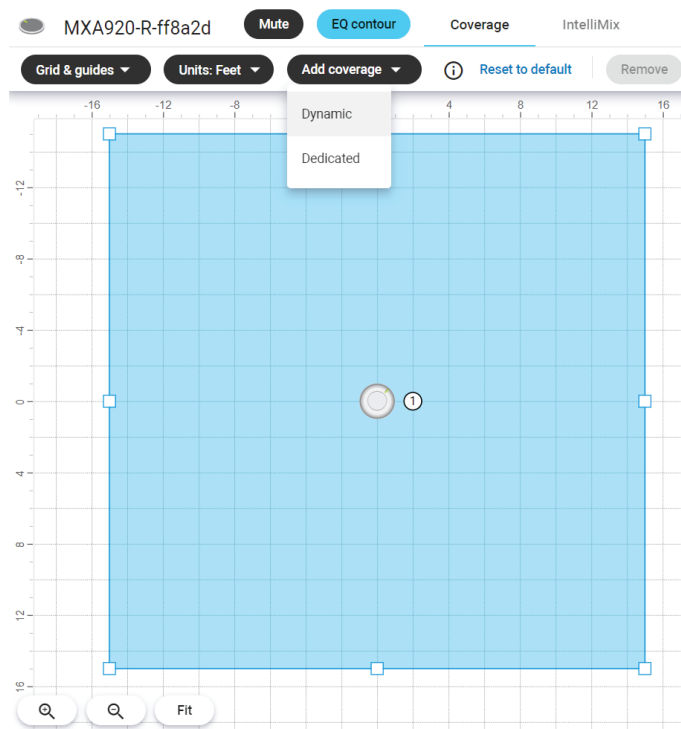

Select Add coverage to add more coverage areas. You can use up to 8 coverage areas per microphone, and you can mix both types as needed. Drag and drop to move coverage areas.

Dynamic Coverage Areas

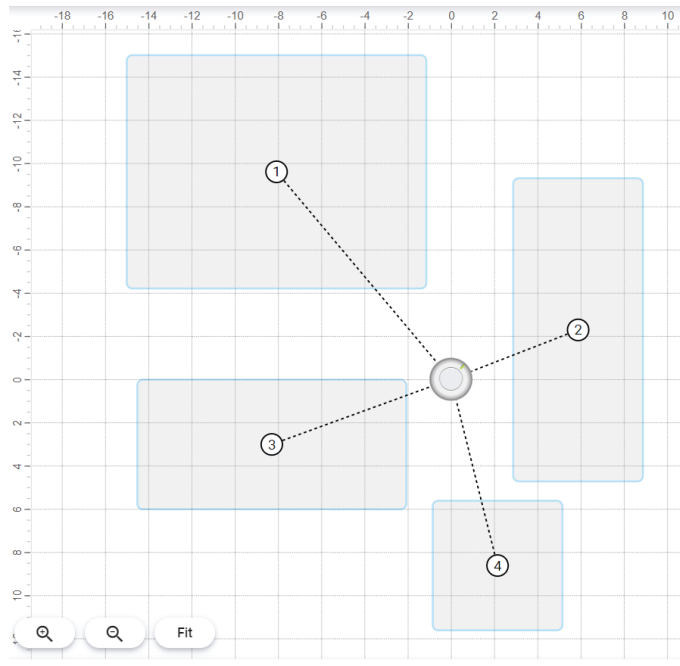

Dynamic coverage areas have flexible coverage, which means that the microphone intelligently adapts to cover all talkers in the coverage area. Change the size to fit your space, and any talker within the boundaries of the coverage area will have microphone coverage (even as they move).

Dedicated Coverage Areas

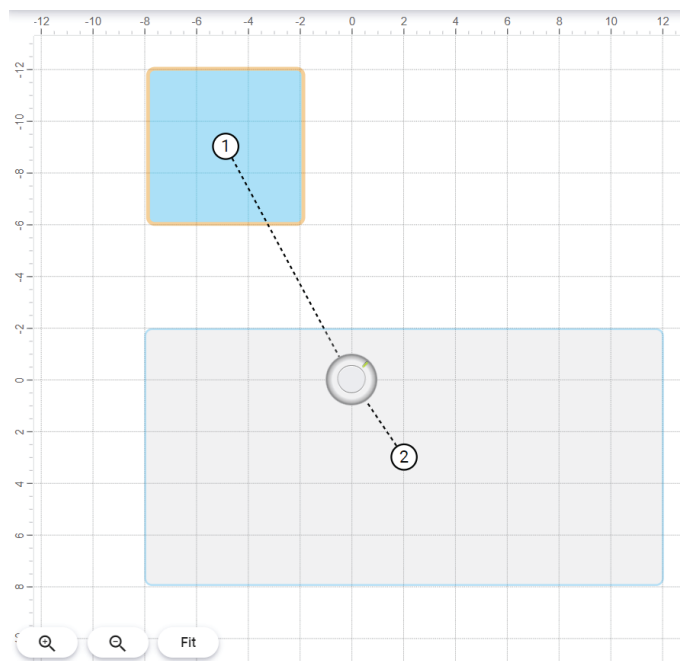

Dedicated coverage areas have microphone coverage at all times. They have a set size of 6 by 6 feet (1.8 by 1.8 meters) and work best for talkers that are in one position most of the time, like at a podium or a whiteboard.

Prevent Unwanted Sounds

As you set up coverage, you may want to block unwanted sounds from your microphone signal (such as doorways or HVAC equipment). There are 2 ways to block unwanted sounds in part of a room:

- Muted coverage
- No coverage

Two Ways to Block Unwanted Sound

| | Muted Coverage | No Coverage |
|--|---|--|
| How does it sound? | Great rejection for unwanted sounds | Good rejection for unwanted sounds |
| Can unwanted sound get picked up? | No. Sounds inside muted coverage areas won't be picked up by active coverage areas. | Possibly. Sounds outside coverage areas can be picked up at low levels by active coverage areas. |
| Does it use coverage areas? | Yes | No |

To use the muted coverage method:

1. Place a coverage area where you want to block unwanted sounds. Select the coverage area.
2. Select Mute in the properties panel. This post-gate mute mutes any sound inside the coverage area.

To use the no coverage method:

- Move or change the size of dynamic coverage areas to avoid the parts of a room with unwanted sounds.
- Move dedicated coverage areas.
- Move or delete extra microphone lobes (when automatic coverage is turned off).

Use Steerable Lobes

Automatic coverage = Off

To use steerable lobes, turn off automatic coverage in Settings > General > Automatic coverage. You can manually position up to 8 microphone lobes. This mode is best for when you need direct outputs, like for a multi-zone voice lift system.

The microphone doesn't use coverage areas when automatic coverage is off.

[See the MXA910 guide to learn more about using lobes.](#)

Adjust Levels

Before adjusting levels:

1. Set up a way to listen to the microphone directly [using a Dante[®] headphone amp](#) or with [Dante Virtual Soundcard](#).
2. Open Designer and find the MXA920 in the list of online devices. Alternatively, launch device's web application.

Automatic Coverage On

1. Talk in each coverage area at a normal speech volume. You can adjust:
 - **Coverage area gain (post-gate):** From the Coverage tab, open the properties panel on the right side. Select the coverage area to see post-gate gain and mute controls.
 - **IntelliMix gain (post-gate):** Go to the IntelliMix tab to adjust the automix out level and control DSP settings.

2. Adjust EQ settings as needed. You can use EQ to improve speech intelligibility and minimize noise. If your EQ changes cause a large increase or decrease in the level, adjust the levels as in step 1.

Automatic Coverage Off

In this mode, there are 2 sets of gain faders:

- **Channel gain (pre-gate):** To adjust, go to Channels. These faders affect a channel's gain before it reaches the automixer and therefore affect the automixer's gating decision. Boosting the gain here will make the lobe more sensitive to sound sources and more likely to gate on. Lowering gain here makes the lobe less sensitive and less likely to gate on. If you're only using direct outputs for each channel without the automixer, you only need to use these faders.
- **IntelliMix gain (post-gate):** To adjust, go to IntelliMix. Alternatively, select a lobe in Coverage to see post-gate gain and mute controls in the properties panel. These faders adjust a channel's gain after the lobe has gated on. Adjusting the gain here will not affect the automixer's gating decision. Only use these faders to adjust the gain of a talker after you are satisfied with the automixer's gating behavior.

Using Designer's Optimize Workflow

Designer's Optimize workflow speeds up the process of connecting systems with at least 1 microphone and 1 audio processor. Optimize also creates mute control routes in rooms with MXA network mute buttons. When you select Optimize in a room, Designer does the following:

- Creates audio routes and mute control routes
- Adjusts audio settings
- Turns on mute synchronization
- Enables LED logic control for applicable devices

The settings are optimized for your particular combination of devices. You can customize settings further, but the Optimize workflow gives you a good starting point.

After optimizing a room, you should check and adjust settings to fit your needs. These steps may include:

- Deleting unnecessary routes.
- Checking levels and adjusting gain.
- Verifying that AEC reference signals are correctly routed.
- Fine-tuning DSP blocks as needed.

Compatible devices:

- MXA910
- MXA920
- MXA710
- MXA310
- P300
- IntelliMix Room
- ANIUSB-MATRIX
- MXN5-C
- MXA Network Mute Button

To use the Optimize workflow:

1. Place all relevant devices in a room.
2. Select Optimize. Designer optimizes microphone and DSP settings for your equipment combination.

If you remove or add devices, select Optimize again.

Mute Sync

Mute sync ensures that all connected devices in a conferencing system mute or unmute at the same time and at the correct point in the signal path. Mute status is synchronized in the devices using logic signals or USB connections.

To use mute sync, make sure logic is enabled on all devices.

Designer's Optimize workflow configures all necessary mute sync settings for you.

Compatible Shure logic devices:

- P300 (Also mutes [supported soft codecs](#) connected by USB)
- ANIUSB-MATRIX (Also mutes [supported soft codecs](#) connected by USB)
- IntelliMix Room software (Also mutes [supported soft codecs](#) connected by USB)
- MXA910
- MXA920
- MXA710
- MXA310
- Network Mute Button
- ANI22-BLOCK
- ANI4IN-BLOCK
- Logic-enabled MX microphones connected to ANI22-BLOCK or ANI4IN-BLOCK
 - MX392
 - MX395-LED
 - MX396
 - MX405/410/415

To use mute sync, route the microphone's signal to a processor that has logic turned on (P300, ANIUSB-MATRIX, or IntelliMix Room software). Microphones always have logic turned on.

For help with specific mute sync implementations, [see our FAQs](#).

How to Install the MXA920

There are many ways to install MXA920 microphones. See below for details about the mounting and accessory options for square and round array microphones.

Installation Best Practices

- Don't place the microphone behind obstructions.
- Coverage depends on your room's acoustics, construction, and materials. Take these into consideration when planning.
- For most rooms, Shure recommends 12 feet (3.7 meters) as the maximum mounting height.

Square mounting options:

- [In a ceiling grid](#)
- [With a VESA mounting device](#)
- [On NPT pole](#)
- [Suspend from ceiling with A900-GM](#)
- [Suspend from ceiling with your own hardware](#)
- [On 3/8-inch threaded rod](#)
- [In a hard ceiling](#)

Round mounting options:

- [With a VESA mounting device](#)
- [On NPT pole](#)
- [Suspend from ceiling with A900-GM](#)
- [Suspend from ceiling with your own hardware](#)
- [On 3/8-inch threaded rod](#)

NOTICE

Due to a preliminary finding by a federal court in the United States, Shure is authorized to ship the MXA920-S-60CM. This model is fully certified and lawful to use anywhere in the world, but is not lawful to be used in the United States in a drop ceiling mounting configuration such as shown below. It is also unlawful to use adapters in an attempt to fit this smaller version into a ceiling grid in the United States such that it mounts substantially as shown below.



Furthermore, the MXA920-S-60CM is not designed or intended to be installed within a 24" ceiling grid, which is the standard grid size in North America. Mounting in such a grid in the above-shown configuration is unsafe and may cause damage to the product and/or injury to those below. The MXA920-S-60CM is safe and lawful for use in other mounting configurations, such as with hard ceilings, or suspended from a VESA pole or suspension wiring, anywhere in the world.

Installing in a Ceiling Grid

Before you begin:

- Remove the plastic cover from the microphone.
- If using, install the rubber pads on the corners of the microphone to prevent scratches.

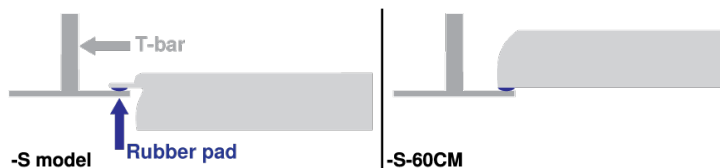

- Verify that your ceiling grid size matches your model variation.
- If using the A910-JB junction box, install it before ceiling installation.

IMPORTANT: Do not install the 60 cm model in a 2 foot (609.6 mm) ceiling grid.

1. Make space in the ceiling grid for the array microphone to be installed.
2. Route the Ethernet cable above the ceiling grid and through the opening in the ceiling.
3. Plug the Ethernet cable in to the microphone.

4. Attach the safety tether between the building structure and one of the tie-off points on the back of the microphone using braided metal cable or other high-strength wire (not included). This safety measure prevents the microphone from falling in an emergency situation. Make sure there is no tension on the safety tether. Follow any local regulations.
5. Install the microphone in the ceiling grid.

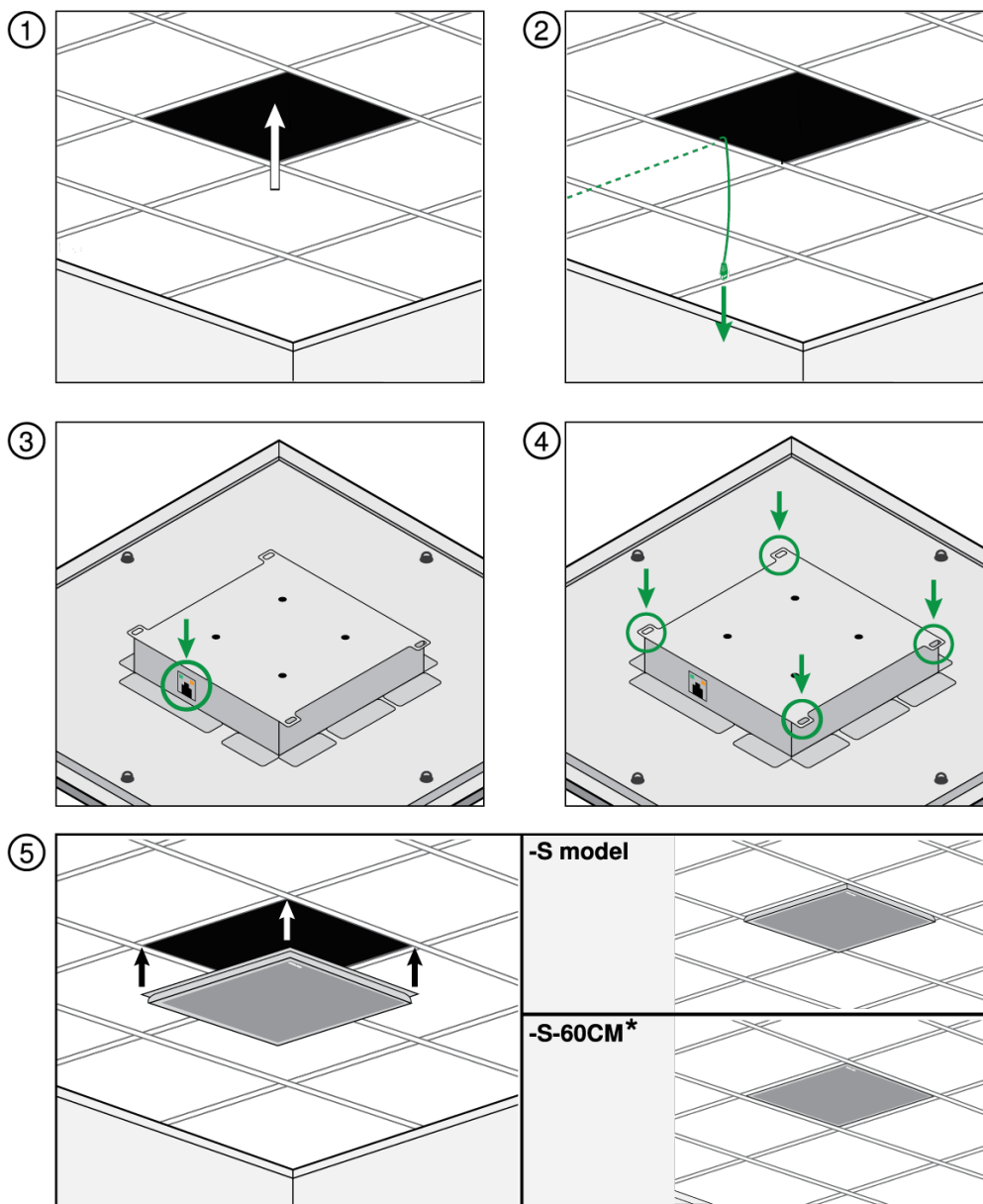

*Flush-mount installation only permissible outside United States.

Installing the Junction Box Accessory

The A910-JB junction box mounts on square ceiling array microphones to connect conduit. There are 3 knockouts on the junction box for attaching conduit. See local regulations to determine if the junction box is necessary.

Note: Install the junction box on the microphone before installing the microphone in the ceiling.

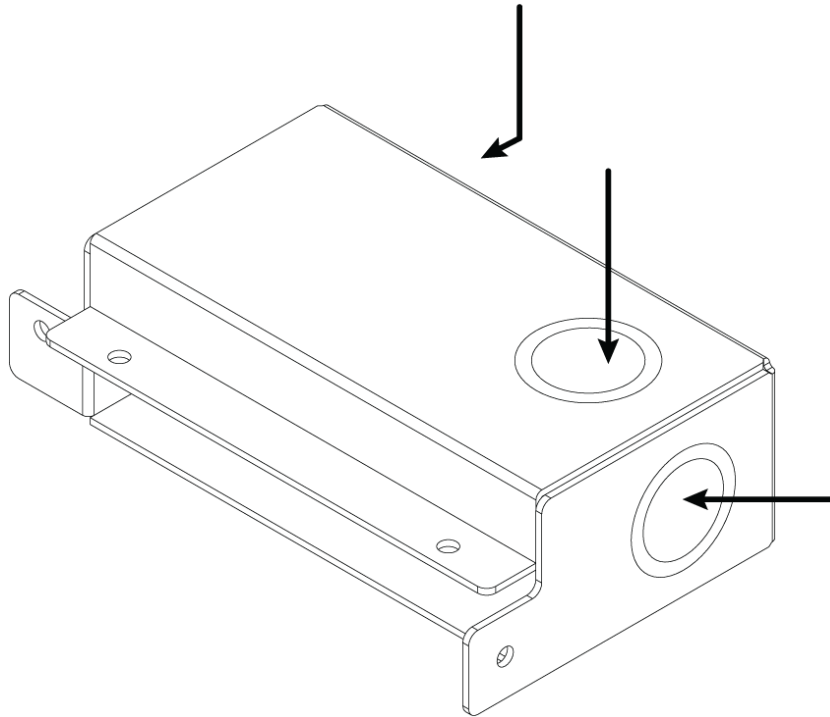
**To install:**

1. Remove the knockout you plan to use on the junction box.
2. Remove the 4 screws from the microphone as shown.

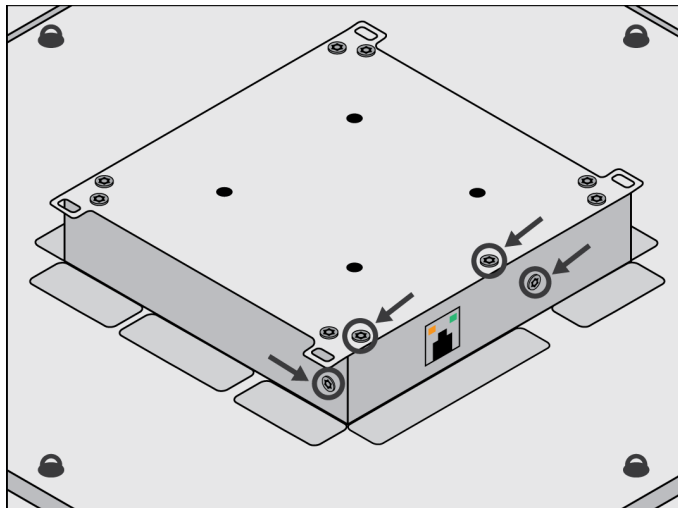

3. Align the junction box with the screw holes. If possible, plug the network cable into the microphone before securing the junction box.
4. Reinstall the 4 screws to secure the junction box to the microphone.

VESA Standardized Mounting

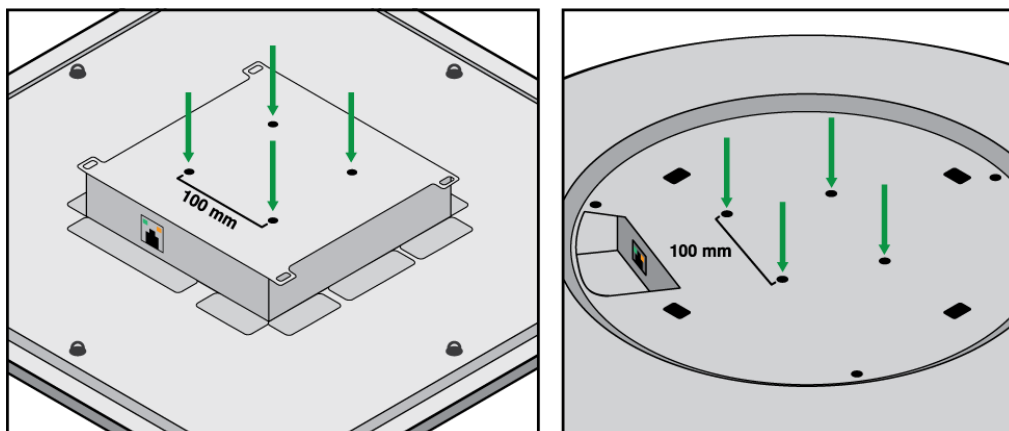

The rear plate has 4 threaded holes for attaching the microphone to a VESA mounting device. The mounting holes follow the VESA MIS-D standard:

- Screw specification: M4 thread (hole depth = 9.15 mm)
- Hole spacing: 100 mm square

The VESA mounting holes work with Shure's [A900-PM](#) and [A900-PM-3/8IN](#) accessories to mount the microphone on a pole.

Suspending from the Ceiling

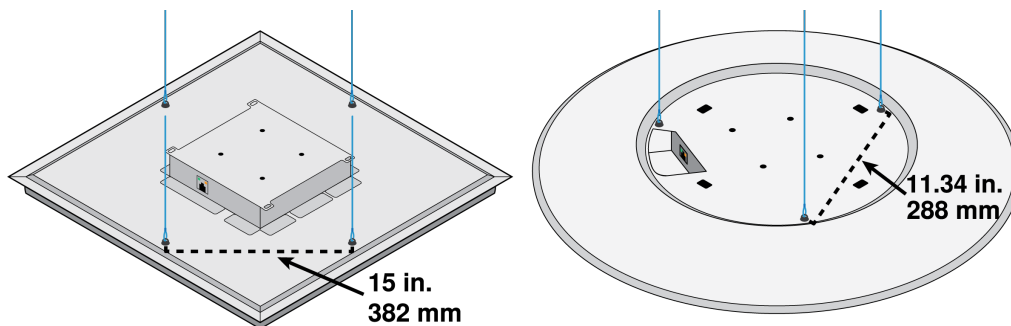

Suspend the microphone using your own equipment, or with Shure's [A900-GM kit](#) (includes mounting cables and hooks).

To mount using your own equipment, you will need:

- Braided metal cable or high-strength wire
 - Hardware to attach cable to ceiling
1. Attach the mounting cables to the 12 mm diameter eyelet screws on the microphone.
 2. Attach the cables to the ceiling using the appropriate hardware.

Hard Ceiling Mounting

You can mount square ceiling array microphones in hard ceilings without a tile grid using the [A910-HCM](#) accessory.

Learn more at www.shure.com.

Dante Channels

The automatic coverage setting changes the number of Dante outputs on the MXA920.

Automatic Coverage On

- 1 automix output with IntelliMix DSP for all coverage areas
- 1 AEC reference input

Note: When automatic coverage is on, Dante Controller shows 8 transmit channels and the automix output. The automix output is the only channel that sends audio with automatic coverage on.

Automatic Coverage Off

- Up to 8 separate Dante outputs (1 for each lobe)
- 1 automix output with IntelliMix DSP
- 1 AEC reference input

IntelliMix DSP

This device contains IntelliMix digital signal processing blocks that can be applied to the microphone's output. The DSP blocks include:

- Acoustic echo cancellation (AEC)
- Automatic gain control (AGC)
- Noise reduction
- Compressor
- Delay

To access, go to the IntelliMix tab.

DSP Best Practices

- Apply DSP blocks as needed. Run a test of your system without DSP, and then add processing as needed to fix any issues that you hear in the audio signal.
- Unless you encounter video that lags behind audio, set delay to off.

Acoustic Echo Cancellation

In audio conferencing, a far-end talker may hear their voice echo as a result of a near-end microphone capturing audio from loudspeakers. Acoustic echo cancellation (AEC) is a DSP algorithm which identifies the far-end signal and stops it from being captured by the microphone to deliver clear, uninterrupted speech. During a conference call, the AEC works constantly to optimize processing as long as far-end audio is present.

When possible, optimize the acoustic environment using the following tips:

- Reduce speaker volume
- Position speakers farther from microphones
- Avoid pointing speakers directly at microphone coverage areas

Selecting a Reference Signal for AEC

To apply AEC, provide a far end reference signal. For best results, use the signal that also feeds your local reinforcement system.

P300: Go to Schematic and click any AEC block. Choose the reference source, and the reference source changes for all AEC blocks.

MXA910, MXA920, MXA710: Route a far-end signal to the AEC Reference In channel.

IntelliMix Room: Go to Schematic and click an AEC block. Choose the reference source. Each block can use a different reference source, so set the reference for each AEC block.

Designer's Optimize workflow automatically routes an AEC reference source, but it's a good idea to check that Designer chooses the reference source you want to use.

AEC Settings

Reference Meter

Use the reference meter to visually verify the reference signal is present. The reference signal should not be clipping.

ERLE

Echo return loss enhancement (ERLE) displays the dB level of signal reduction (the amount of echo being removed). If the reference source is connected properly, the ERLE meter activity generally corresponds to the reference meter.

Reference

Indicates which channel is serving as the far end reference signal.

Non-Linear Processing

The primary component of the acoustic echo canceller is an adaptive filter. Non-linear processing supplements the adaptive filter to remove any residual echo caused by acoustic irregularities or changes in the environment. Use the lowest possible setting that is effective in your room.

Low: Use in rooms with controlled acoustics and minimal echoes. This setting provides the most natural sound for full duplex.

Medium: Use in typical rooms as a starting point. If you hear echo artifacts, try using the high setting.

High: Use to provide the strongest echo reduction in rooms with bad acoustics, or in situations where the echo path frequently changes.

Noise Reduction

Noise reduction significantly reduces the amount of background noise in your signal caused by projectors, HVAC systems, or other environmental sources. It is a dynamic processor, which calculates the noise floor in the room and removes noise throughout the entire spectrum with maximum transparency.

Settings

The noise reduction setting (low, medium, or high) represents the amount of reduction in dB. Use the lowest possible setting that effectively lowers noise in the room.

Automatic Gain Control (AGC)

Automatic gain control automatically adjusts channel levels to ensure consistent volume for all talkers, in all scenarios. For quieter voices, it increases gain; for louder voices, it attenuates the signal.

Enable AGC on channels where the distance between the talker and the microphone may vary, or in rooms where many different people will use the conferencing system.

Automatic gain control happens post-gate (after the automixer), and will not affect when the automixer gates on or off.

Target Level (dBFS)

Use -37 dBFS as a starting point to ensure adequate headroom, and adjust if necessary. This represents the RMS (average) level, which is different from setting the input fader according to peak levels to avoid clipping.

Maximum Boost (dB)

Sets the maximum amount of gain that can be applied

Maximum Cut (dB)

Sets the maximum attenuation that can be applied

Tip: Use the boost/cut meter to monitor the amount of gain added or subtracted from the signal. If this meter is always reaching the maximum boost or cut level, consider adjusting the input fader so the signal is closer to the target level.

Delay

Use delay to synchronize audio and video. When a video system introduces latency (where you hear someone speak, and their mouth moves later), add delay to align audio and video.

Delay is measured in milliseconds. If there is a significant difference between audio and video, start by using larger intervals of delay time (500-1000 ms). When the audio and video are slightly out of sync, use smaller intervals to fine-tune.

Compressor

Use the compressor to control the dynamic range of the selected signal.

Threshold

When the audio signal exceeds the threshold value, the level is attenuated to prevent unwanted spikes in the output signal. The amount of attenuation is determined by the ratio value. Perform a soundcheck and set the threshold 3-6 dB above average talker levels, so the compressor only attenuates unexpected loud sounds.

Ratio

The ratio controls how much the signal is attenuated when it exceeds the threshold value. Higher ratios provide stronger attenuation. A lower ratio of 2:1 means that for every 2 dB the signal exceeds the threshold, the output signal will only exceed the threshold by 1 dB. A higher ratio of 10:1 means a loud sound that exceeds the threshold by 10 dB will only exceed the threshold by 1 dB, effectively reducing the signal by 9 dB.

Parametric Equalizer

Maximize audio quality by adjusting the frequency response with the parametric equalizer.

Common equalizer applications:

- Improve speech intelligibility
- Reduce noise from HVAC systems or video projectors
- Reduce room irregularities
- Adjust frequency response for reinforcement systems

Setting Filter Parameters

Adjust filter settings by manipulating the icons in the frequency response graph, or by entering numeric values. Disable a filter using the check-box next to the filter.

| | |
|--------------------|---|
| Filter Type | <p>Only the first and last band have selectable filter types.</p> <p>Parametric: Attenuates or boosts the signal within a customizable frequency range</p> <p>Low Cut: Rolls off the audio signal below the selected frequency</p> <p>Low Shelf: Attenuates or boosts the audio signal below the selected frequency</p> <p>High Cut: Rolls off the audio signal above the selected frequency</p> <p>High Shelf: Attenuates or boosts the audio signal above the selected frequency</p> |
| Frequency | Select the center frequency of the filter to cut/boost |
| Gain | Adjusts the level for a specific filter (+/- 30 dB) |
| Q | Adjusts the range of frequencies affected by the filter. As this value increases, the bandwidth becomes thinner. |
| Width | <p>Adjusts the range of frequencies affected by the filter. The value is represented in octaves.</p> <p>Note: the Q and width parameters affect the equalization curve in the same way. The only difference is the way the values are represented.</p> |

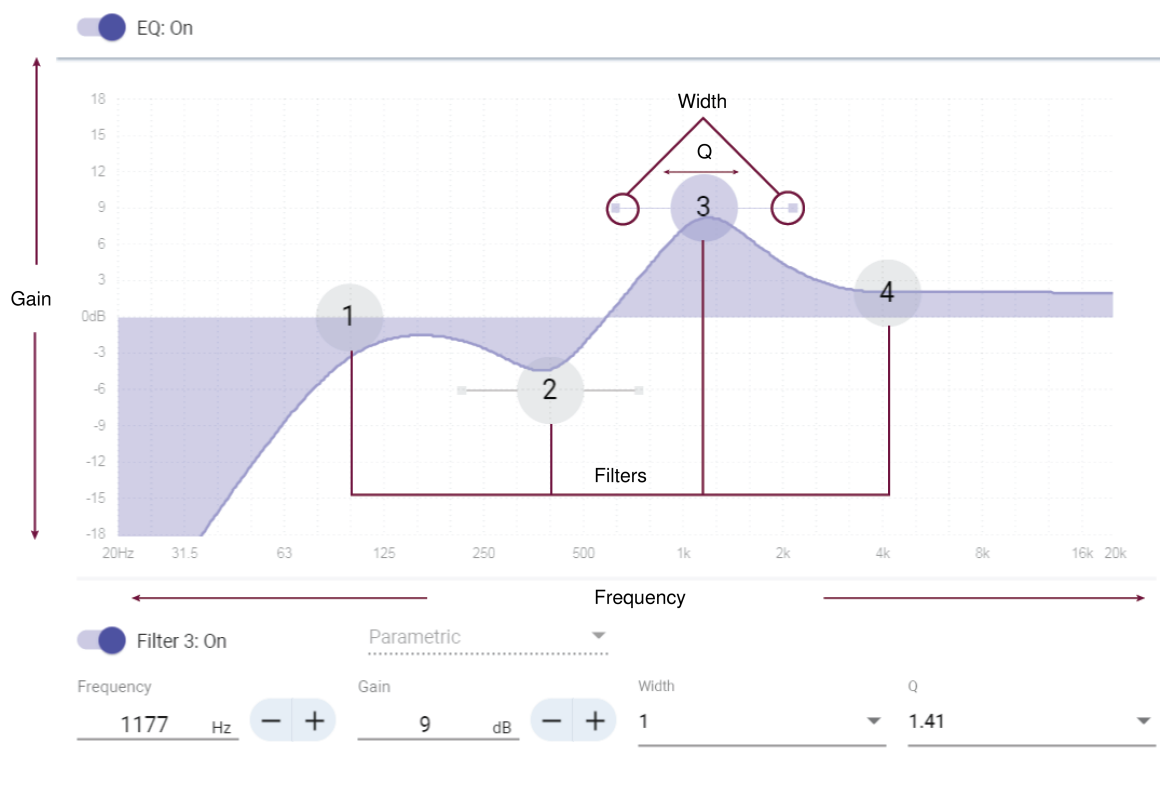

Copy, Paste, Import, and Export Equalizer Channel Settings

These features make it simple to use effective equalizer settings from a previous installation, or simply accelerate configuration time.

Copy and Paste

Use to quickly apply the same PEQ setting across multiple channels.

1. Select the channel from the pull-down menu in the PEQ screen.
2. Select Copy
3. In the pull-down menu, select the channel to apply the PEQ setting and select Paste.

Import and Export

Use to save and load PEQ settings from a file on a computer. This is useful for creating a library of reusable configuration files on computers used for system installation.

| | |
|---------------|--|
| Export | Choose a channel to save the PEQ setting, and select Export to file. |
| Import | Choose a channel to load the PEQ setting, and select Import from file. |

Equalizer Applications

Conferencing room acoustics vary based on room size, shape, and construction materials. Use the guidelines in following table.

| EQ Application | Suggested Settings |
|---|--|
| Treble boost for improved speech intelligibility | Add a high shelf filter to boost frequencies greater than 1 kHz by 3-6 dB |
| HVAC noise reduction | Add a low cut filter to attenuate frequencies below 200 Hz |
| Reduce flutter echoes and sibilance | Identify the specific frequency range that "excites" the room: <ol style="list-style-type: none"> 1. Set a narrow Q value 2. Increase the gain to between +10 and +15 dB, and then experiment with frequencies between 1 kHz and 6 kHz to pinpoint the range of flutter echoes or sibilance 3. Reduce the gain at the identified frequency (start between -3 and -6 dB) to minimize the unwanted room sound |
| Reduce hollow, resonant room sound | Identify the specific frequency range that "excites" the room: <ol style="list-style-type: none"> 1. Set a narrow Q value 2. Increase the gain to between +10 and +15 dB, and then experiment with frequencies between 300 Hz and 900 Hz to pinpoint the resonant frequency |

| EQ Application | Suggested Settings |
|----------------|---|
| | <ol style="list-style-type: none"> 3. Reduce the gain at the identified frequency (start between -3 and -6 dB) to minimize the unwanted room sound |

EQ Contour

Use the EQ contour to quickly apply a high-pass filter at 150 Hz to the microphone's signal.

Select EQ contour to turn it on or off.

Encryption

Audio is encrypted with the Advanced Encryption Standard (AES-256), as specified by the US Government National Institute of Standards and Technology (NIST) publication FIPS-197. Shure devices that support encryption require a passphrase to make a connection. Encryption is not supported with third-party devices.

In Designer, you can only enable encryption for all devices in a room in live mode: [Your room] > Settings > Audio-encryption.

To activate encryption in the web application:

1. Go to Settings > Audio encryption > Enable encryption.
2. Enter a passphrase. All devices must use the same passphrase to establish an encrypted connection.

Important: For encryption to work:

- All Shure devices on your network must use encryption.
- Disable AES67 in Dante Controller. AES67 and AES-256 cannot be used at the same time.

Networking Best Practices

When connecting Shure devices to a network, use the following best practices:

- Always use a "star" network topology by connecting each device directly to the switch or router.
- Connect all Shure networked devices to the **same network** and set to the **same subnet**.
- Allow all Shure software through the firewall on your computer.
- Use only 1 DHCP server per network. Disable DHCP addressing on additional servers.
- Power on the switch and DHCP server before powering on the Shure devices.
- To expand the network, use multiple switches in a star topology.
- All devices must be at the same firmware revision level.

Switch and Cable Recommendations for Dante Networking

Switches and cables determine how well your audio network performs. Use high-quality switches and cables to make your audio network more reliable.

Network switches should have:

- Gigabit ports. 10/100 switches may work on small networks, but gigabit switches perform better.
- Power over Ethernet (PoE) or PoE+ ports for any devices that require power

- Management features to provide information about port speed, error counters, and bandwidth used
- Ability to switch off Energy Efficient Ethernet (EEE). EEE (also known as "Green Ethernet") may cause audio dropouts and problems with clock synchronization.
- Diffserv (DSCP) Quality of Service (QoS) with strict priority and 4 queues

Ethernet cables should be:

- Cat5e or better
- Shielded

For more information, [see our FAQ](#) about switches to avoid.

Device IP Configuration

This Shure device uses 2 IP addresses: one for Shure control, and one for Dante audio and control.

- **Shure control**
 - Carries data for Shure control software, firmware updates, and third-party control systems (such as AMX or Crestron)
- **Dante audio and control**
 - Carries Dante digital audio and control data for Dante Controller
 - Requires a wired, gigabit Ethernet connection to operate

To access these settings in Designer, go to [Your device] > Settings > IP configuration.

Setting Latency

Latency is the amount of time for a signal to travel across the system to the outputs of a device. To account for variances in latency time between devices and channels, Dante has a predetermined selection of latency settings. When the same setting is selected, it ensures that all Dante devices on the network are in sync.

These latency values should be used as a starting point. To determine the exact latency to use for your setup, deploy the setup, send Dante audio between your devices, and measure the actual latency in your system using Audinate's Dante Controller software. Then round up to the nearest latency setting available, and use that one.

Use Audinate's Dante Controller software to change latency settings.

Latency Recommendations

| Latency Setting | Maximum Number of Switches |
|------------------|----------------------------|
| 0.25 ms | 3 |
| 0.5 ms (default) | 5 |
| 1 ms | 10 |
| 2 ms | 10+ |

QoS (Quality of Service) Settings

QoS settings assign priorities to specific data packets on the network, ensuring reliable audio delivery on larger networks with heavy traffic. This feature is available on most managed network switches. Although not required, assigning QoS settings is recommended.

Note: Coordinate changes with the network administrator to avoid disrupting service.

To assign QoS values, open the switch interface and use the following table to assign Dante[®]-associated queue values.

- Assign the highest possible value (shown as 4 in this example) for time-critical PTP events

- Use descending priority values for each remaining packet.

Dante QoS Priority Values

| Priority | Usage | DSCP Label | Hex | Decimal | Binary |
|-------------------|--------------------------|------------|------|---------|--------|
| High (4) | Time-critical PTP events | CS7 | 0x38 | 56 | 111000 |
| Medium (3) | Audio, PTP | EF | 0x2E | 46 | 101110 |
| Low (2) | (reserved) | CS1 | 0x08 | 8 | 001000 |
| None (1) | Other traffic | BestEffort | 0x00 | 0 | 000000 |

Note: Switch management may vary by manufacturer and switch type. Consult the manufacturer's product guide for specific configuration details.

For more information on Dante requirements and networking, visit www.audinate.com.

Networking Terminology

PTP (Precision Time Protocol): Used to synchronize clocks on the network

DSCP (Differentiated Services Code Point): Standardized identification method for data used in layer 3 QoS prioritization

IP Ports and Protocols

Shure Control

| Port | TCP/UDP | Protocol | Description | Factory Default |
|--------------|---------|------------------------------|---|-----------------|
| 21 | TCP | FTP | Required for firmware updates (otherwise closed) | Closed |
| 22 | TCP | SSH | Secure Shell Interface | Closed |
| 23 | TCP | Telnet | Not supported | Closed |
| 53 | UDP | DNS | Domain Name System | Closed |
| 67 | UDP | DHCP | Dynamic Host Configuration Protocol | Open |
| 68 | UDP | DHCP | Dynamic Host Configuration Protocol | Open |
| 80* | TCP | HTTP | Required to launch embedded web server | Open |
| 443 | TCP | HTTPS | Not supported | Closed |
| 2202 | TCP | ASCII | Required for 3rd party control strings | Open |
| 5353 | UDP | mDNS [†] | Required for device discovery | Open |
| 5568 | UDP | SDT (multicast) [†] | Required for inter-device communication | Open |
| 57383 | UDP | SDT (unicast) | Required for inter-device communication | Open |
| 8023 | TCP | Telnet | Debug console interface | Closed |
| 8180 | TCP | HTML | Required for web application (legacy firmware only) | Open |

| Port | TCP/UDP | Protocol | Description | Factory Default |
|-------|---------|------------------------------|---|-----------------|
| 8427 | UDP | SLP (multicast) [†] | Required for inter-device communication | Open |
| 64000 | TCP | Telnet | Required for Shure firmware update | Open |

*These ports must be open on the PC or control system to access the device through a firewall.

[†]These protocols require multicast. Ensure multicast has been correctly configured for your network.

See [Audinate's website](#) for information about ports and protocols used by Dante audio.

Digital Audio Networking

Dante digital audio is carried over standard Ethernet and operates using standard internet protocols. Dante provides low latency, tight clock synchronization, and high Quality-of-Service (QoS) to provide reliable audio transport to a variety of Dante devices. Dante audio can coexist safely on the same network as IT and control data, or can be configured to use a dedicated network.

Compatibility with Dante Domain Manager

This device is compatible with Dante Domain Manager software (DDM). DDM is network management software with user authentication, role-based security, and auditing features for Dante networks and Dante-enabled products.

Considerations for Shure devices controlled by DDM:

- When you add Shure devices to a Dante domain, set the local controller access to Read Write. Otherwise, you won't be able to access to Dante settings, perform a factory reset, or update device firmware.
- If the device and DDM can't communicate over the network for any reason, you won't be able to control Dante settings, perform a factory reset, or update device firmware. When the connection is reestablished, the device follows the policy set for it in the Dante domain.
- If Dante device lock is on, DDM is offline, or the configuration of the device is set to Prevent, some device settings are disabled. These include: Dante encryption, MXW association, AD4 Dante browse and Dante cue, and SCM820 linking.

See [Dante Domain Manager's documentation](#) for more information.

Dante Flows for Shure Devices

Dante flows get created any time you route audio from one Dante device to another. One Dante flow can contain up to 4 audio channels. For example: sending all 5 available channels from an MXA310 to another device uses 2 Dante flows, because 1 flow can contain up to 4 channels.

Every Dante device has a specific number of transmit flows and receive flows. The number of flows is determined by Dante platform capabilities.

Unicast and multicast transmission settings also affect the number of Dante flows a device can send or receive. Using multicast transmission can help overcome unicast flow limitations.

Shure devices use different Dante platforms:

| Dante Platform | Shure Devices Using Platform | Unicast Transmit Flow Limit | Unicast Receive Flow Limit |
|----------------|--|-----------------------------|----------------------------|
| Brooklyn II | ULX-D, SCM820, MXWAPT, MXWANI, P300, MXCWAPT | 32 | 32 |

| Dante Platform | Shure Devices Using Platform | Unicast Transmit Flow Limit | Unicast Receive Flow Limit |
|----------------------------|---|-----------------------------|----------------------------|
| Brooklyn II (without SRAM) | MXA920, MXA910, MXA710, AD4 | 16 | 16 |
| Ultimo/UltimoX | MXA310, ANI4IN, ANI4OUT, ANIUSB-MATRIX, ANI22, MXN5-C | 2 | 2 |
| DAL | IntelliMix Room | 16 | 16 |

Learn more about Dante flows in our [FAQs](#) or from [Audinate](#).

AES67

AES67 is a networked audio standard that enables communication between hardware components which use different IP audio technologies. This Shure device supports AES67 for increased compatibility within networked systems for live sound, integrated installations, and broadcast applications.

The following information is critical when transmitting or receiving AES67 signals:

- Update Dante Controller software to the newest available version to ensure the AES67 configuration tab appears.
- Before turning encryption on or off, you must disable AES67 in Dante Controller.
- AES67 cannot operate when the transmit and receive devices both support Dante.

| Shure Device Supports: | Device 2 Supports: | AES67 Compatibility |
|------------------------|---|---------------------|
| Dante and AES67 | Dante and AES67 | No. Must use Dante. |
| Dante and AES67 | AES67 without Dante. Any other audio networking protocol is acceptable. | Yes |

Separate Dante and AES67 flows can operate simultaneously. The total number of flows is determined by the maximum flow limit of the device.

Sending Audio from a Shure Device

All AES67 configuration is managed in Dante Controller software. For more information, refer to the Dante Controller user guide.

1. Open the Shure transmitting device in Dante Controller.
2. Enable AES67.
3. Reboot the Shure device.
4. Create AES67 flows according to the instructions in the [Dante Controller user guide](#).

Receiving Audio from a Device Using a Different Audio Network Protocol

Third-party devices: When the hardware supports SAP, flows are identified in the routing software that the device uses. Otherwise, to receive an AES67 flow, the AES67 session ID and IP address are required.

Shure devices: The transmitting device must support SAP. In Dante Controller, a transmit device (appears as an IP address) can be routed like any other Dante device.

Paint the MXA920

Painting Square Array Microphones

You can paint the grille and frame of square ceiling array microphones to blend in with a room's design.

Step 1: Remove the Frame and Grille

1. On each side of the frame, remove the 6 screws and washers that attach the main assembly to the frame.

Important: Do not remove the 4 recessed screws in each corner.

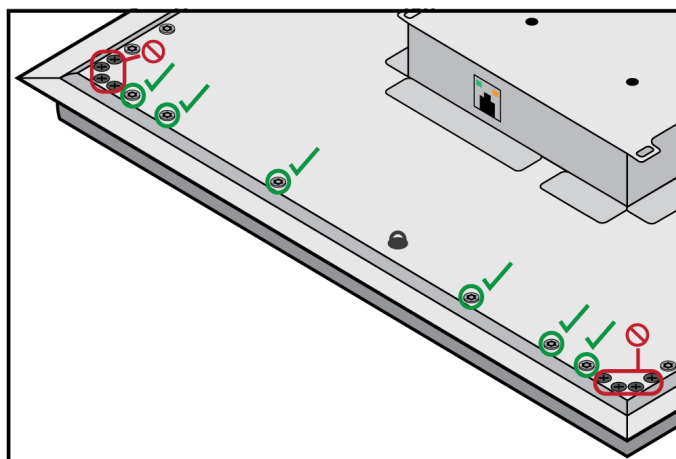

2. Carefully lift the assembly out of the frame.
3. Remove the gray plastic LED lightpipe. Leave the black plastic guide in place.
4. Remove all 4 recessed screws from one side of the frame. Remove that side of the frame.

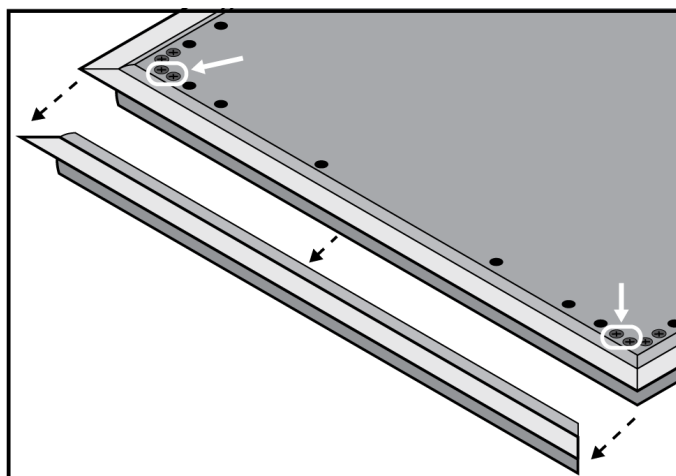

5. Slide the flat grille out of the frame.
6. Carefully remove the foam piece from the grille. Pull from the edges, where it is attached with hook-and-loop fastener strips.

Important: Do not paint the foam.

7. Before painting, reinstall the side of the frame you removed in step 1.4.

Step 2: Mask and Paint

1. Use masking tape to cover the entire extrusion (highlighted in black) that runs along the inside of the frame. This ensures that the necessary metal pieces make contact when reassembled.

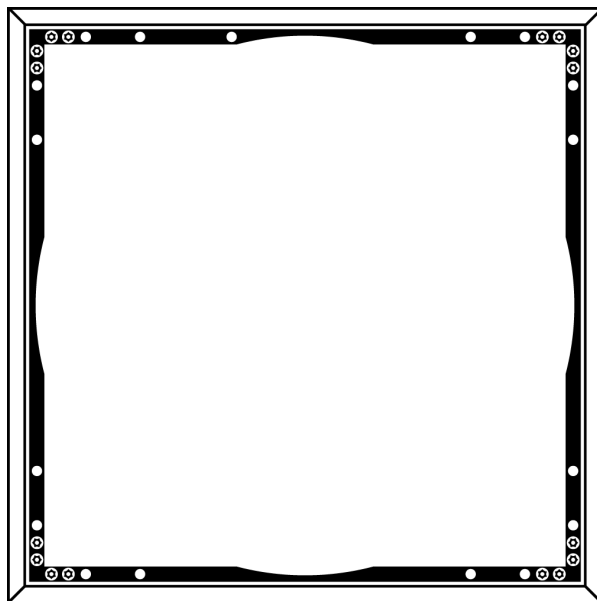

2. Use masking tape to cover the hook-and-loop fastener strips on the grille.
3. Paint the frame and grille. Let them dry completely before reassembling. Do not paint any part of the main assembly.

Step 3: Reassembly

1. Attach the foam piece to the grille with the hook-and-loop fastener strips.
2. Remove one side of the frame as in step 1.4. Slide the grille back into the frame.
3. Attach the remaining side of the frame and secure it with the 4 screws.
4. Attach the LED lightpipe to the black plastic guide piece.
5. Align the LED with the lightpipe and put the main assembly back in place on the frame.

Note: The label on the assembly is in the corner that corresponds to the LED.

6. Install 6 screws per side to secure the main assembly to the frame. Do not over-tighten.

Painting Round Array Microphones

The grille and back cover of round array microphones can be painted to blend in with a room's design.

Step 1: Remove and Paint the Grille

1. Loosen the set screw that connects the grille to the back cover. Turn the microphone over.

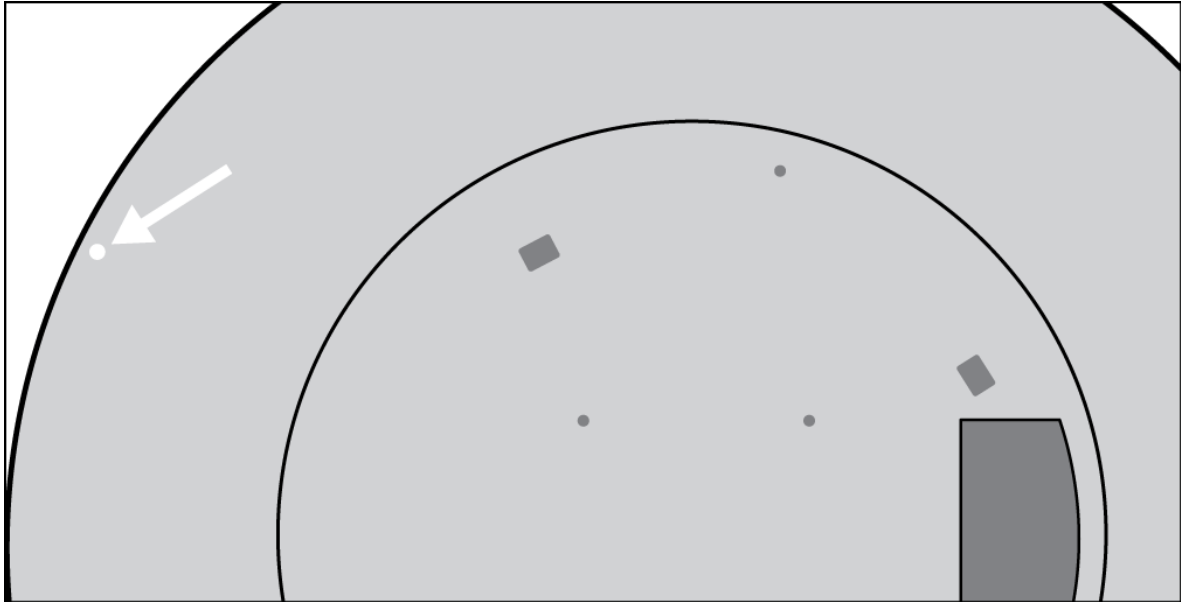

2. Rotate the grille as shown to release it from the back cover. Lift it up and out of the tabs holding it in place.

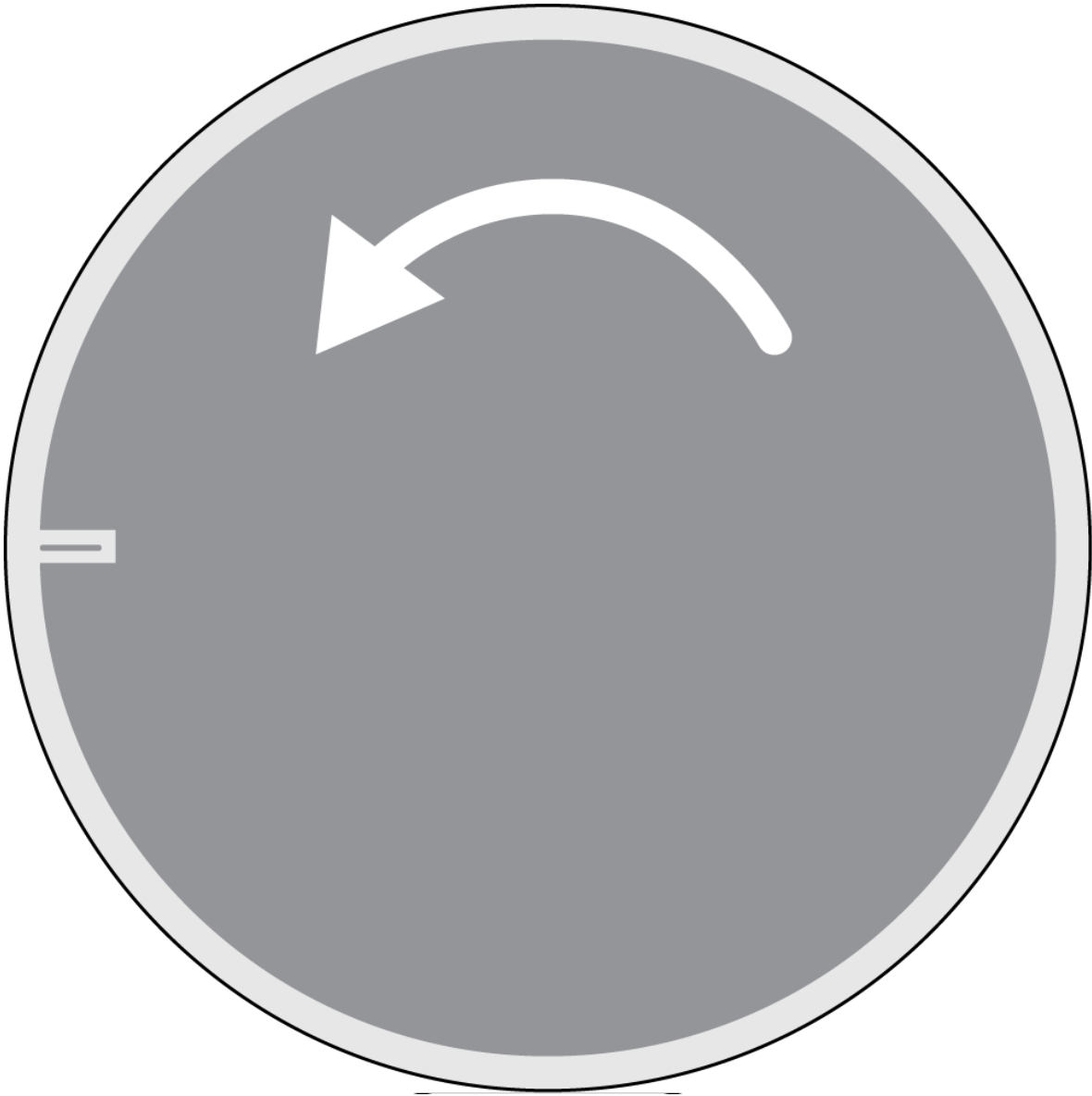

3. Carefully remove the fabric piece from the grille. Pull from the edges where it is attached with Velcro strips. Do not paint the fabric.
4. Hold the edges of the black plastic guide in place and pull up on the clear lightpipe to unsnap it. Leave the guide in place.
5. Mask the 7 bare metal tabs on the grille.

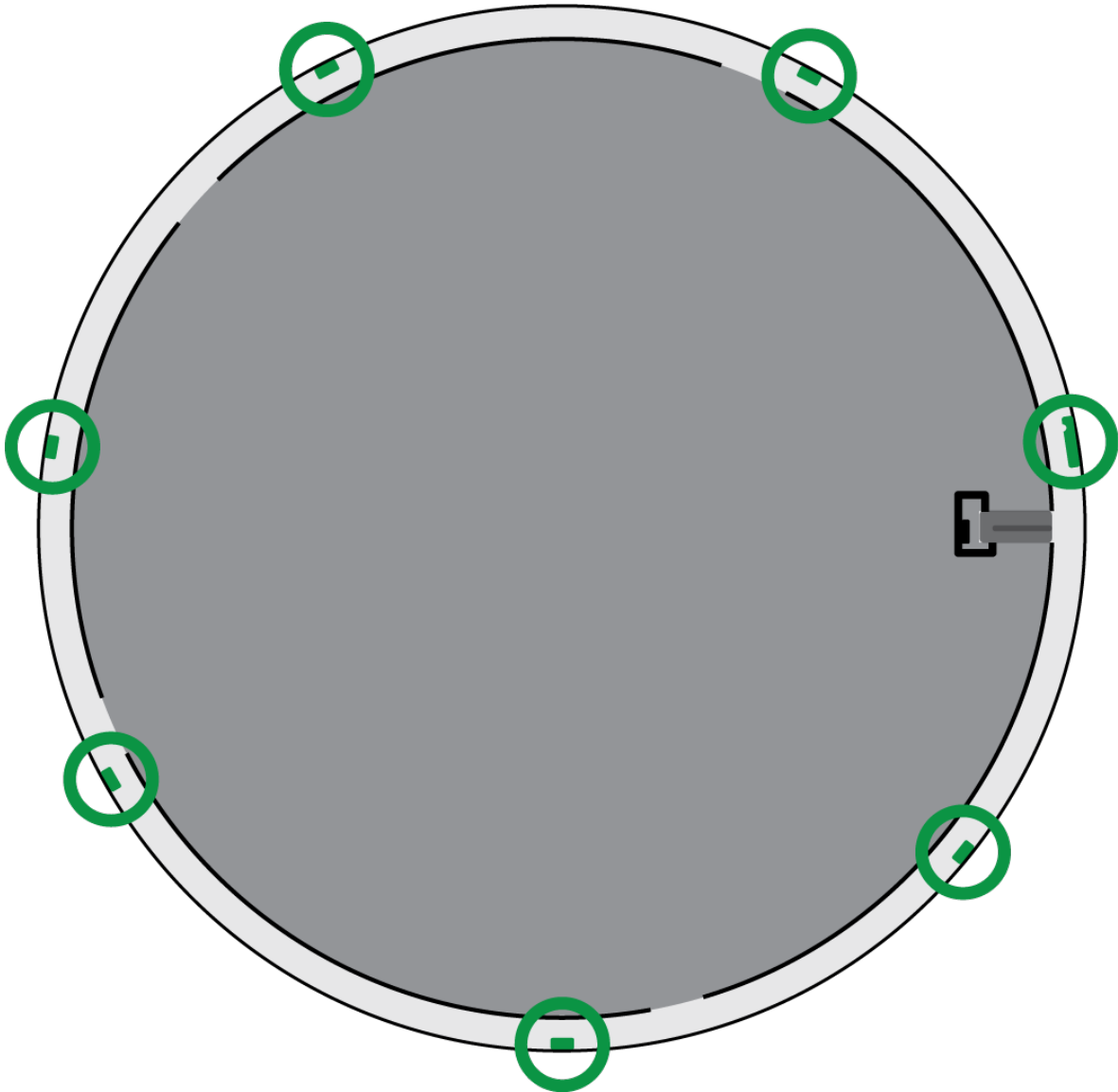

6. Paint the grille.

Step 2: Remove and Paint the Back Cover

1. Remove the 7 screws on the aluminum support panel. Turn the back cover over.

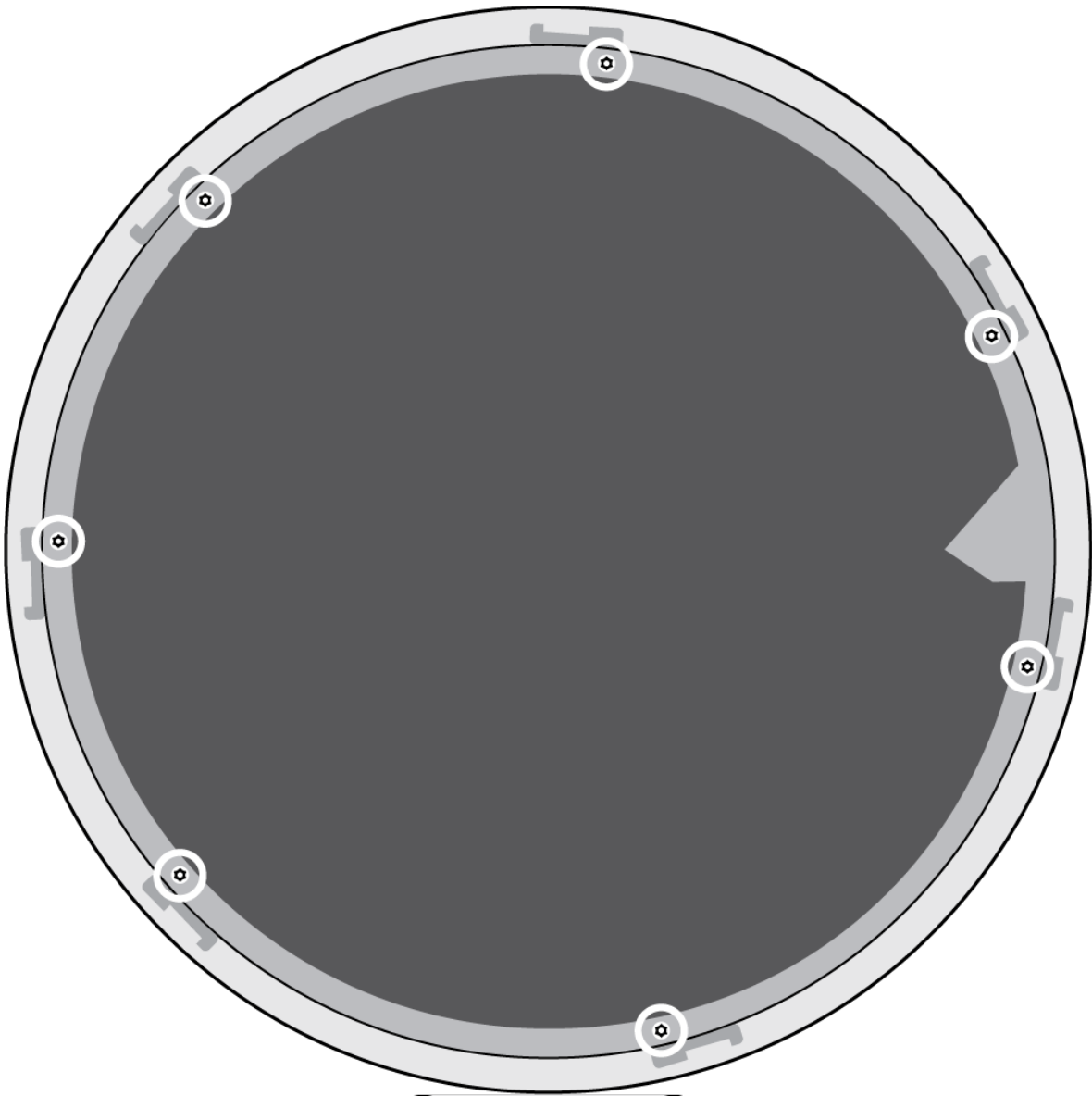

2. Remove the 12 screws that attach the back cover to the processor enclosure. Set the processor enclosure aside with the black board facing up.

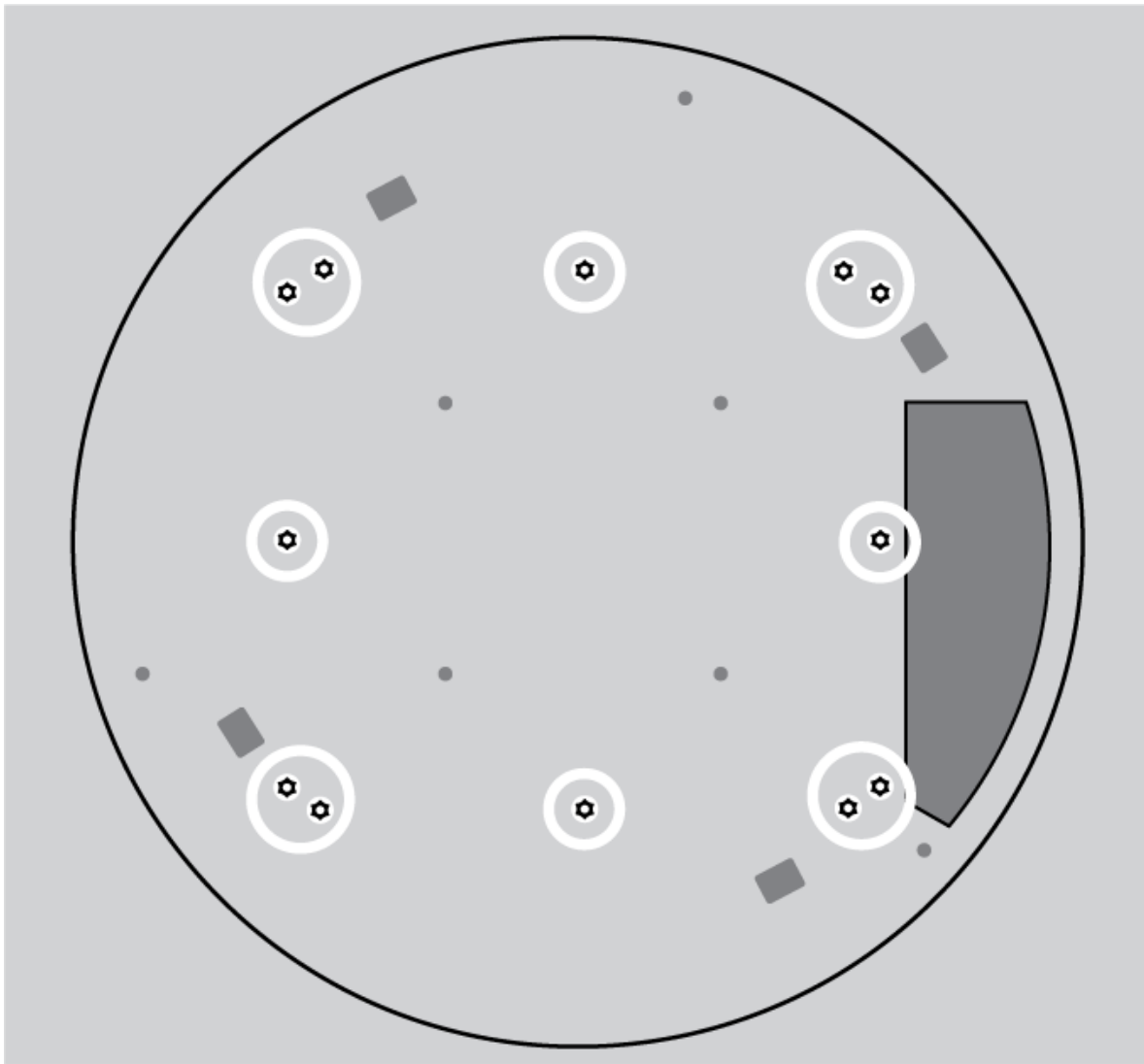

3. Mask the entire flat area in the center of the back cover. Mask the 7 tabs on the inside of the back cover to keep paint out of the screw threads.
4. Paint the outside of the back cover.

Step 3: Reassemble the Microphone

Let the paint dry before reassembling.

1. Use the 12 screws to attach the back cover to the processor.
2. Use the 7 screws to reattach the aluminum support panel.
3. Reinstall the lightpipe on the grille by snapping it into place.
4. Attach the fabric piece to the grille.
5. Align the grille with the 7 tabs on the back cover. Set it down and rotate the grille as shown to engage the tabs.

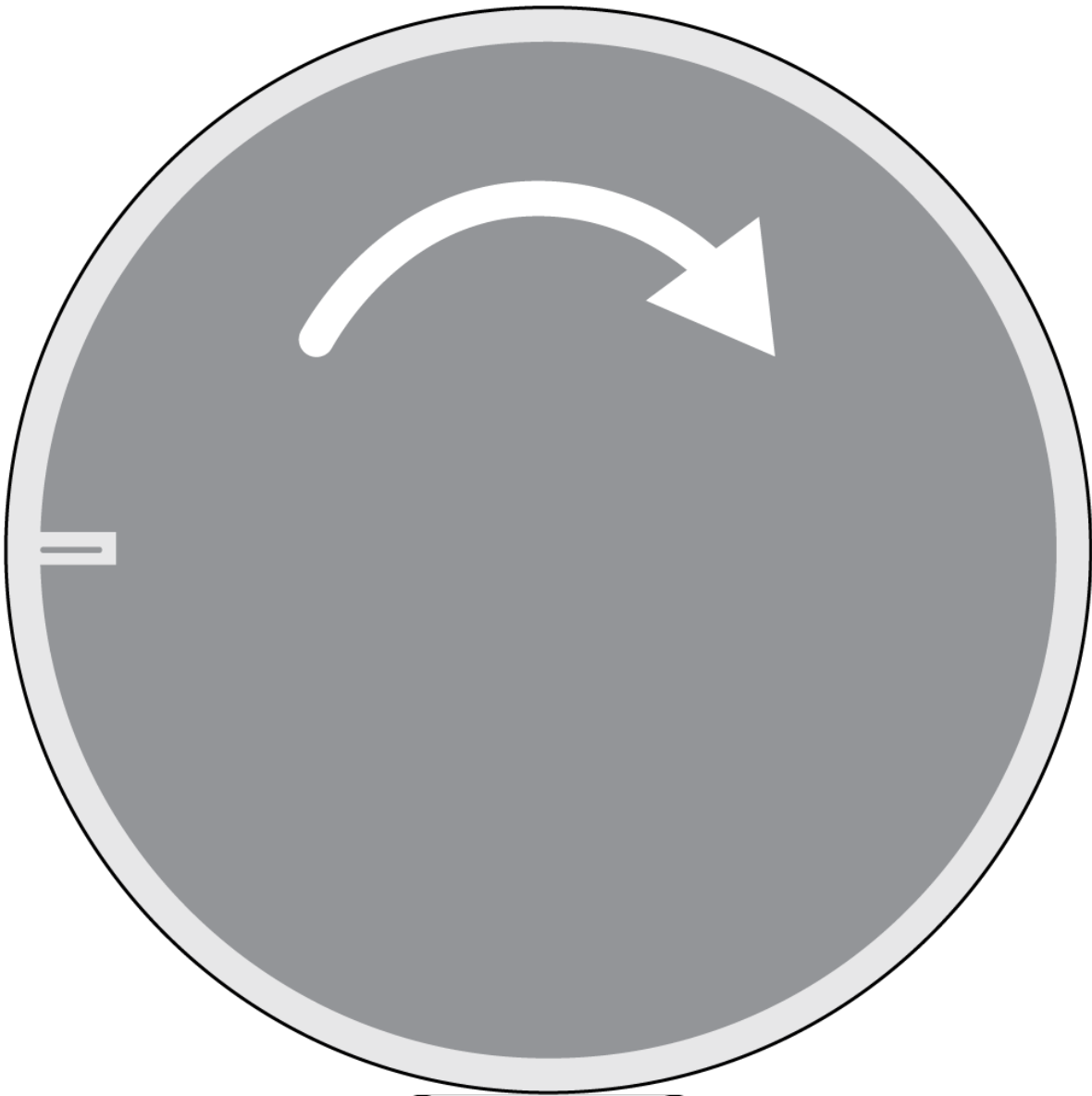

6. Tighten the set screw.

Using Command Strings

This device receives logic commands over the network. Many parameters controlled through Designer can be controlled using a third-party control system, using the appropriate command string.

Common applications:

- Mute
- LED color and behavior
- Loading presets
- Adjusting levels

A complete list of command strings is available at:

pubs.shure.com/command-strings/MXA920.

Integrate the MXA920 with Camera Control Systems

MXA920 microphones provide information about talker position, lobe position, and other settings through command strings. You can use this information to integrate the microphone with camera control systems.

See the [list of commands for camera systems](#) to learn more.

Troubleshooting

| Problem | Solution |
|---|---|
| Audio is not present or is quiet/distorted | <p>Check cables.</p> <p>Verify that output channel isn't muted.</p> <p>Check that output levels are not set too low.</p> |
| Sound quality is muffled or hollow | <p>Check that coverage area is positioned correctly.</p> <p>Use EQ to adjust frequency response.</p> |
| Microphone does not power on | <p>Check that microphone is plugged in to a Power over Ethernet (PoE) port on the switch.</p> <p>Check network cables and connections.</p> |
| Microphone doesn't show up in Designer or Shure Web Device Discovery | <p>Ensure that microphone has power.</p> <p>Make sure microphone is on the same network and subnet as PC.</p> <p>Turn off network interfaces not used to connect to the device (such as Wi-Fi).</p> <p>Check that DHCP server is functioning (if applicable).</p> <p>Reset the device if necessary.</p> |
| Flashing red error LED | <p>Go to [Your device] > Settings > General > Export log to export the device event log. Designer also has an event log in the main menu that collects information for all Designer devices. Use the event logs to get more information, and contact Shure if necessary.</p> |
| No lights | <p>Go to [Your device] > Settings > Lights. Check if brightness is disabled or if any other settings are turned off.</p> |
| Web application lags in Google Chrome browser | <p>Turn off hardware acceleration option in Chrome.</p> |

For more help:

- [Contact Shure](#)
- Sign up for training with the [Shure Audio Institute](#)

Specifications

General

Coverage Type

Automatic or steerable

Power Requirements

Power over Ethernet (PoE), Class 0

Power Consumption

10.1 W maximum

Control Software

Designer or web application

Plenum Rating

| | |
|-----------------|---|
| MXA920-S | UL2043 (Suitable for Air Handling Spaces) |
| MXA920-R | Not rated |

Dust Protection

IEC 60529 IP5X Dust Protected

Operating Temperature Range

-6.7°C (20°F) to 40°C (104°F)

Storage Temperature Range

-29°C (-20°F) to 74°C (165°F)

Networking

Cable Requirements

Cat5e or higher (shielded cable recommended)

Connector Type

RJ45

Audio

AES67 or Dante Digital Output

| | | |
|--------------------------------|-------------------------------------|---|
| Chan- nel Count | Automatic cover- age on | 2 total channels (1 output, 1 AEC reference in channel) |
| | Automatic cover- age off | 10 total channels (8 independent transmit channels, 1 automix output, 1 AEC reference in channel) |

| | |
|----------------------|--------|
| Sampling Rate | 48 kHz |
| Bit Depth | 24 |

Sensitivity

at 1 kHz

-1.74 dBFS/Pa

Maximum SPL

Relative to 0 dBFS overload

95.74 dB SPL

Signal-to-Noise Ratio

Ref. 94 dB SPL at 1 kHz

75.76 dB A-weighted

Latency

Does not include Dante latency

| | |
|--|---------|
| Direct outputs (Automatic coverage off) | 15.9 ms |
| Automix output (Includes IntelliMix processing) | 26.6 ms |

Self Noise

18.24 dB SPL-A

Dynamic Range

77.5 dB

Digital Signal Processing

Automatic mixing, acoustic echo cancellation (AEC), noise reduction, automatic gain control, compressor, delay, equalizer (4-band parametric), mute, gain (140 dB range)

Acoustic Echo Cancellation Tail Length

Up to 250 ms

Frequency Response

125 Hz to 20,000 Hz

MXA920 Frequency Response

Frequency response measured directly on-axis from a distance of 6 feet (1.83 m).

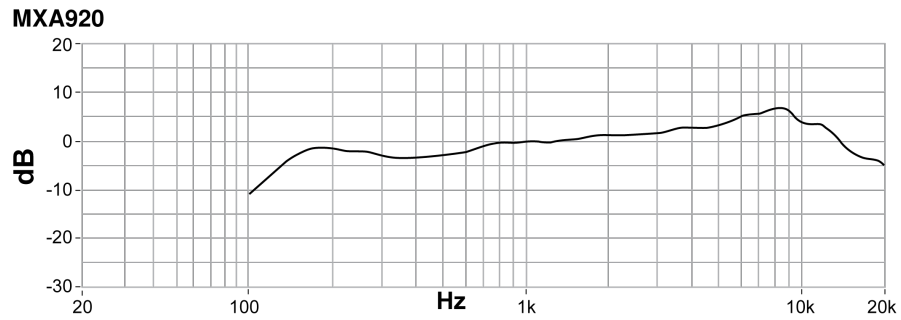

Dimensions

Weight

- MXA920-S: 11.8 lbs (5.4 kg)
- MXA920-R: 12.7 lbs (5.8 kg)

MXA920-S



- A (Microphone flange): 0.41 in. (10.5 mm)
- B (Edge to edge): 23.77 in. (603.8 mm)
- C (Height): 2.15 in. (54.69 mm)

MXA920-S-60CM

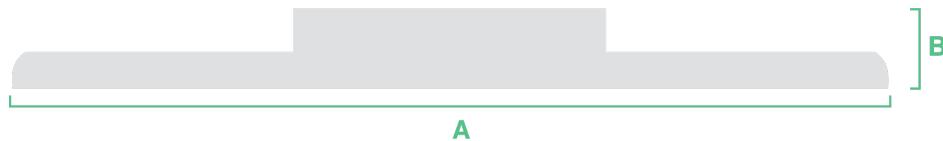

- A (Edge to edge): 23.38 in. (593.8 mm)
- B (Height): 2.15 in. (54.69 mm)

MXA920-R



- A (Height to top of eyelets): 2.4 in. (61.3 mm)
- B (Outer diameter): 25 in. (635.4 mm)

IMPORTANT SAFETY INSTRUCTIONS



1. READ these instructions.
2. KEEP these instructions.
3. HEED all warnings.
4. FOLLOW all instructions.
5. DO NOT use this apparatus near water.
6. CLEAN ONLY with dry cloth.
7. DO NOT block any ventilation openings. Allow sufficient distances for adequate ventilation and install in accordance with the manufacturer's instructions.
8. DO NOT install near any heat sources such as open flames, radiators, heat registers, stoves, or other apparatus (including amplifiers) that produce heat. Do not place any open flame sources on the product.
9. DO NOT defeat the safety purpose of the polarized or grounding type plug. A polarized plug has two blades with one wider than the other. A grounding type plug has two blades and a third grounding prong. The wider blade or the third prong are provided for your safety. If the provided plug does not fit into your outlet, consult an electrician for replacement of the obsolete outlet.
10. PROTECT the power cord from being walked on or pinched, particularly at plugs, convenience receptacles, and the point where they exit from the apparatus.
11. ONLY USE attachments/accessories specified by the manufacturer.
12. USE only with a cart, stand, tripod, bracket, or table specified by the manufacturer, or sold with the apparatus. When a cart is used, use caution when moving the cart/apparatus combination to avoid injury from tip-over.



13. UNPLUG this apparatus during lightning storms or when unused for long periods of time.
14. REFER all servicing to qualified service personnel. Servicing is required when the apparatus has been damaged in any way, such as power supply cord or plug is damaged, liquid has been spilled or objects have fallen into the apparatus, the apparatus has been exposed to rain or moisture, does not operate normally, or has been dropped.
15. DO NOT expose the apparatus to dripping and splashing. DO NOT put objects filled with liquids, such as vases, on the apparatus.
16. The MAINS plug or an appliance coupler shall remain readily operable.
17. The airborne noise of the Apparatus does not exceed 70dB (A).
18. Apparatus with CLASS I construction shall be connected to a MAINS socket outlet with a protective earthing connection.
19. To reduce the risk of fire or electric shock, do not expose this apparatus to rain or moisture.

20. Do not attempt to modify this product. Doing so could result in personal injury and/or product failure.

21. Operate this product within its specified operating temperature range.

| | |
|---|---|
|  | This symbol indicates that dangerous voltage constituting a risk of electric shock is present within this unit. |
|  | This symbol indicates that there are important operating and maintenance instructions in the literature accompanying this unit. |

Important Product Information

The equipment is intended to be used in professional audio applications.

This device is to be connected only to PoE networks without routing to the outside plant.

Note: This device is not intended to be connected directly to a public internet network.

Changes or modifications not expressly approved by Shure Incorporated could void your authority to operate this equipment.

Note: Testing is based on the use of supplied and recommended cable types. The use of other than shielded (screened) cable types may degrade EMC performance.

Please follow your regional recycling scheme for batteries, packaging, and electronic waste.

Information to the user

This equipment has been tested and found to comply with the limits for a Class B digital device, pursuant to part 15 of the FCC Rules. This equipment generates, uses, and can radiate radio frequency energy and, if not installed and used in accordance with the manufacturer's instruction manual, may cause interference with radio and television reception.

Notice: The FCC regulations provide that changes or modifications not expressly approved by Shure Incorporated could void your authority to operate this equipment.

These limits are designed to provide reasonable protection against harmful interference in a residential installation. This equipment generates uses and can radiate radio frequency energy and, if not installed and used in accordance with the instructions, may cause harmful interference to radio communications. However, there is no guarantee that interference will not occur in a particular installation. If this equipment does cause harmful interference to radio or television reception, which can be determined by turning the equipment off and on, the user is encouraged to try to correct the interference by one or more of the following measures:

- Reorient or relocate the receiving antenna.
- Increase the separation between the equipment and the receiver.
- Connect the equipment to an outlet on a circuit different from that to which the receiver is connected.
- Consult the dealer or an experienced radio/TV technician for help.

This device complies with part 15 of the FCC Rules. Operation is subject to the following two conditions:

1. This device may not cause harmful interference.
2. This device must accept any interference received, including interference that may cause undesired operation.

This Class B digital apparatus complies with Canadian ICES-003. Cet appareil numérique de la classe B est conforme à la norme NMB-003 du Canada.

CAN ICES-003 (B)/NMB-003(B)

The CE Declaration of Conformity can be obtained from: www.shure.com/europe/compliance

Authorized European representative:

Shure Europe GmbH
 Global Compliance
 Jakob-Dieffenbacher-Str. 12
 75031 Eppingen, Germany
 Phone: +49-7262-92 49 0
 Email: info@shure.de
 www.shure.com

This product meets the Essential Requirements of all relevant European directives and is eligible for CE marking.

The CE Declaration of Conformity can be obtained from Shure Incorporated or any of its European representatives. For contact information please visit www.shure.com

| 部件名称 | 有害物质 | | | | | |
|--------|------|---|---|-----|------|-------|
| | 铅 | 汞 | 镉 | 六价铬 | 多溴联苯 | 多溴二苯醚 |
| 电路模块 | X | ○ | ○ | ○ | ○ | ○ |
| 金属模块 | X | ○ | ○ | ○ | ○ | ○ |
| 线缆及其组件 | X | ○ | ○ | ○ | ○ | ○ |
| 外壳 | ○ | ○ | ○ | ○ | ○ | ○ |
| 电源适配器* | X | ○ | ○ | ○ | ○ | ○ |
| 电池组* | X | ○ | ○ | ○ | ○ | ○ |

本表格依据SJ/T11364的规定编制。

○: 表示该有害物质在该部件所有均质材料中的含量均在GB/T26572规定的限量要求以下。

X: 表示该有害物质至少在该部件某一均质材料中的含量超出GB/T26572规定的限量要求。

注: 本产品大部分的部件采用无害的环保材料制造, 含有有害物质的部件皆因全球技术发展水平的限制而无法实现有害物质的替代。

*:表示如果包含部分